

BIPMIC[®] – Cascadable Silicon Bipolar Amplifier

Electrostatic sensitive device.
Observe precautions for handling.



Applications

General purpose 50 Ω gain block for narrow and broad band IF and RF amplifiers in commercial and industrial applications. The 50 Ω level allows directly to cascade this

amplifier with minimal external circuitry, thus providing a simple, cost effective way to achieve low level amplification.

Features

- Broadband amplification
- Low operating voltage (6 V)
- 50 Ω cascadable gain block
- High gain (17.5 dB at 900 MHz)
- Low noise figure (3.3 dB at 900 MHz)
- Low cost surface mount plastic package
- Few external components

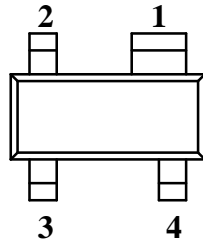

94 9279

S858TA1 Marking: 858

Plastic case (SOT 143)

1 = RF-input; 2 = Ground; 3 = RF-output; 4 = Ground

Absolute Maximum Ratings

| Parameters | Symbol | Value | Unit |
|---|-----------|-------------|------------------|
| Device current | I_d | 35 | mA |
| RF input power | P_{in} | +20 | dBm |
| Total power dissipation $T_{amb} \leq 60^\circ\text{C}$ | P_{tot} | 200 | mW |
| Junction temperature | T_j | 150 | $^\circ\text{C}$ |
| Storage temperature range | T_{stg} | -65 to +150 | $^\circ\text{C}$ |

Maximum Thermal Resistance

| Parameters | Symbol | Value | Unit |
|--|------------|-------|------|
| Junction ambient mounted on glass fibre printed board (25 x 20 x 1.5) mm ³ plated with 35 μm Cu | R_{thJA} | 450 | K/W |

Electrical AC Characteristics

$I_d = 29 \text{ mA}$, $Z_0 = 50 \text{ } \Omega$, $T_{\text{amb}} = 25^\circ\text{C}$

| Parameters / Test Conditions | Symbol | Min. | Typ. | Max. | Unit |
|---|---------------------|------|-------|------|------|
| Power gain f = 900 MHz | G_p | 17 | 17.5 | | dB |
| 3 dB bandwidth | $f_{3\text{dB}}$ | | 0.5 | | GHz |
| Input VSWR f = 0.1 to 2.5 GHz | VSWR | | 1.8:1 | | |
| Output VSWR f = 0.1 to 2.5 GHz | VSWR | | 1.8:1 | | |
| 50 Ω noise figure f = 900 MHz | F | | 3.3 | | dB |
| Output power at 1 dB compression | P_{Out1dB} | | 5 | | dBm |
| Device voltage | V_d | 4.0 | 5.0 | 6.0 | V |

Dimensions in mm

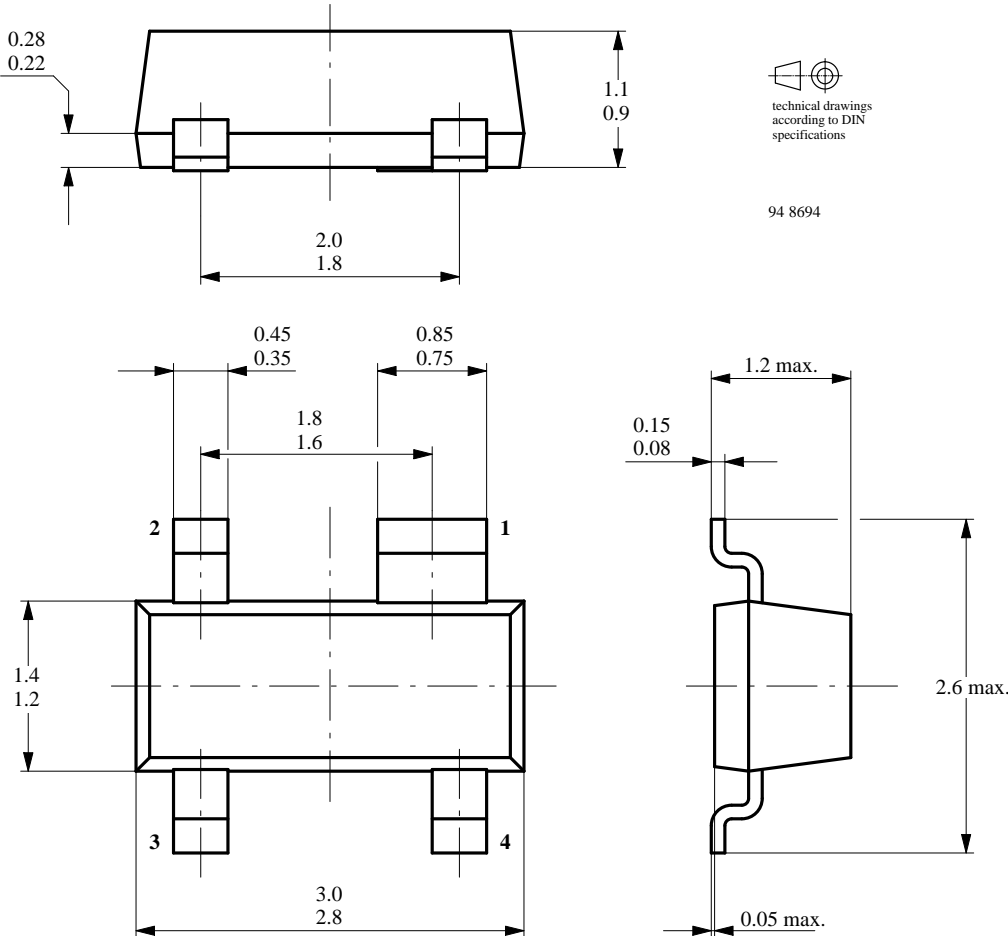

Ozone Depleting Substances Policy Statement

It is the policy of **TEMIC TELEFUNKEN microelectronic GmbH** to

1. Meet all present and future national and international statutory requirements.
2. Regularly and continuously improve the performance of our products, processes, distribution and operating systems with respect to their impact on the health and safety of our employees and the public, as well as their impact on the environment.

It is particular concern to control or eliminate releases of those substances into the atmosphere which are known as ozone depleting substances (ODSs).

The Montreal Protocol (1987) and its London Amendments (1990) intend to severely restrict the use of ODSs and forbid their use within the next ten years. Various national and international initiatives are pressing for an earlier ban on these substances.

TEMIC TELEFUNKEN microelectronic GmbH semiconductor division has been able to use its policy of continuous improvements to eliminate the use of ODSs listed in the following documents.

1. Annex A, B and list of transitional substances of the Montreal Protocol and the London Amendments respectively
2. Class I and II ozone depleting substances in the Clean Air Act Amendments of 1990 by the Environmental Protection Agency (EPA) in the USA
3. Council Decision 88/540/EEC and 91/690/EEC Annex A, B and C (transitional substances) respectively.

TEMIC can certify that our semiconductors are not manufactured with ozone depleting substances and do not contain such substances.

We reserve the right to make changes to improve technical design without further notice.

Parameters can vary in different applications. All operating parameters must be validated for each customer application by the customer. Should the buyer use TEMIC products for any unintended or unauthorized application, the buyer shall indemnify TEMIC against all claims, costs, damages, and expenses, arising out of, directly or indirectly, any claim of personal damage, injury or death associated with such unintended or unauthorized use.

TEMIC TELEFUNKEN microelectronic GmbH, P.O.B. 3535, D-74025 Heilbronn, Germany
Telephone: 49 (0)7131 67 2831, Fax Number: 49 (0)7131 67 2423